

# AT30 SERIES

*Microprocessor Controlled Float Battery Charger*



***Looking for the world's premium  
microprocessor controlled float battery charger?***

***The AT30 is the world's easiest to operate float battery charger. It has over 10 years of proven reliability and has become the industry's "gold standard" for all stationary battery charging applications. We are so confident in our product that we have backed the AT30 with our unrivaled 5 Year Standard Warranty.***



CSA C22.2 · NRTL/C · UL 1012/UL 1564 compliant  
Seismic qualified  
ABS · CE certification available upon request

JF5018

# HBL

## What is the AT30?

Combining the performance and accuracy of a microprocessor with the reliability of SCR power conversion technology makes the AT Series the standard in stationary battery chargers. AT30s are easy to install, operate and maintain. The AT30 is packed with the most standard features and best warranty in the industry.

## What are the most common applications for the AT30?



### Utility & Communications

Power Generation  
Substations  
Microwave Relay Sites  
Switchgear



### Manufacturing

Emergency DC Power  
DC Operated Breakers  
Alarm Systems



### Commercial

Alarm Systems  
Uninterrupted Power Systems  
DC Control Systems

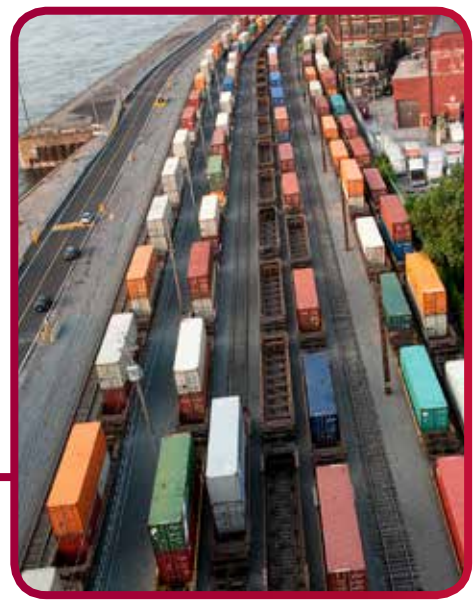

### Transportation

Signal Systems  
Switchgear  
Alarm Systems

# SPECIFICATIONS & STANDARD FEATURES

## SPECIFICATIONS

### AC Input

- **Voltage:**
  - 208 Vac 60Hz
  - 240 Vac 60Hz
  - 480 Vac 60Hz
  - 550-600 Vac 60Hz
  - 220 Vac 50/60Hz
  - 380 Vac 50/60Hz
  - 416 Vac 50/60Hz
- **Input Voltage Tolerance:**
  - +10%, -12%
- **Input Frequency Tolerance:**
  - ±5%
- **Efficiency:**
  - 85-90% typical for 130Vdc at 50-100% load

### DC Output

- **Voltage Ratings:**
  - 12, 24, 48, or 130Vdc nominal
- **Current Ratings (A dc):**
  - 25, 30, 40, 50, 75, 100, 125, 150, 200, 250, 300, 400, 500, 600, 800, 1000
- **Continuous Rating:**
  - 110% rated current at maximum equalize voltage at 50°C
- **Current Limit Adjustment Range:**
  - 50% to 110% rated output
- **Voltage Regulation:**
  - ±0.25% for line, load and temp. variations
  - \*Regulation at max. equalize voltages may not meet ±0.25%*
- **Electrical Noise:**
  - 32dBnc
- **Ripple:**
  - 12/24/48Vdc
    - Unfiltered on battery 1% Vrms
    - Filtered on battery 30mVrms
    - Filtered off battery 1% Vrms
    - Battery Eliminator 30mVrms
  - 130Vdc
    - Unfiltered on battery 2% Vrms
    - Filtered on battery 100mVrms
    - Filtered off battery 2% Vrms
    - Battery Eliminator 100mVrms
- **Surge Withstand Capability:**
  - Meets IEEE-472, ANSI C37.90a

### Safety and Acceptance

- Meets NEMA PE 5-1996, PE5-1997 (R2003) specifications
- NEMA Type 1 / IP20 standard enclosure

- Third party agency approvals:



- CSA C22.2 compliant (up to and including 400A)
  - NRTL/C · UL 1012/UL 1564 compliant
- Seismic qualified (5018/5030 cabinet styles only)
- ABS or CE certification available upon request.

- Made in the United States of America

### Environmental

- Operating Ambient Temperature 0°F to 122°F (-18°C to 50°C) w/o derating
- Operating Altitude 10,000 feet (3,000 meters) above sea level w/o derating
- Relative Humidity 0% to 95% (without condensation)
- Audible Noise Less than 65 dBA at any point 5ft (1.5m) from any vertical surface of enclosure

## STANDARD FEATURES

- 5 Year Product Warranty
- Universal main control board operates in any AT Series charger
- Alarm assembly with local LEDs and summary relay contact for AC Failure, DC Failure, High Vdc, Low Vdc, Positive(+) and Negative(-) ground fault
- High DC voltage shutdown
- Forced load share during parallel operation
- Float/equalize selector switch with indicating lights
- Manual equalize timer (0-255 hr.) with indicating lights
- AC line failure automatic equalize timer (0-255 hr.) with indicating light
- AC On indicating light
- 1% Digital LED meter for Vdc, A dc, timer hours and alarm settings
- 6 pulse rectification
- AC input and DC output circuit breakers
- Membrane front panel
- Front panel controls can be disabled for security
- A redundant analog circuit for LVDC alarm, independent of the microprocessor
- Redundant control loops for higher reliability
- Local or remote voltage sense with redundancy to protect against remote sense failure
- Self-diagnostics
- Input & output MOV surge suppressors
- Reverse polarity protection via free wheeling diodes
- CU-AL I/O compression lugs
- Switchboard wire, UL VW-1
- Enclosure pre-treated using a 5-stage iron phosphate process with baked epoxy powder coating in ANSI 61 gray

# CUSTOMIZE YOUR AT30

OPTIONS THAT LET YOU DESIGN YOUR CHARGER EXACTLY HOW YOU NEED IT!

## SUMMARY OF OPTIONS

- DC output filtering: per NEMA PE5 1996, standard and battery eliminator
- Medium & High AIC Breakers
- AC Input/DC output fuses
- Auxiliary alarm relay board
- Copper ground bus
- AC lightning arrestor
- Fungus proofing (tropicalization)
- Static proofing
- Forced load share cable
- Communications module: DNP3 Level 2 or MODBUS protocols
- Battery temp. compensation
- Custom Paint
- NEMA 4 (12) type enclosure w/fan
- NEMA Type 2 Drip Shield
- Barrier type alarm terminal block
- End of discharge alarm
- Battery discharge alarm
- Zero-center ground detection meter
- Analog AC voltmeter
- Analog AC ammeter
- Cabinet heater assembly
- CE marking upon request
- ABS certification upon request
- Fan control contactor
- Custom drawing package (DWG/PDF)
- Mechanical lock for front door



### Filtering STANDARD

Output filtering is essential whenever there is need for low ac ripple and low noise on the dc bus for critical loads. The standard dc output filtering limits ripple to no more than 30mV RMS on 12, 24 & 48Vdc units, and 100mV RMS on 130Vdc units, measured at the battery terminals. This feature meets the specifications of NEMA standard PE5-1996, and is recommended for installations using VRLA or gelled electrolyte batteries.

### BATTERY ELIMINATOR

An additional "battery eliminator" feature is also available, meeting the specifications of NEMA standard PE5-1996 with no battery connected, measured at the dc output terminals. This feature is recommended for sites where the battery may occasionally be disconnected from the dc bus for maintenance. Additional filtering is essential to limit ac ripple and noise for critical dc loads.

ORDERING	
FACTORY INSTALLATION <b>YES</b>	Factory Installation use Specification Table on page 11
AVAILABLE FOR FIELD INSTALLATION <b>YES</b>	Contact factory with serial number of original unit and type of filtering upgrade.



### Medium & High AIC Breaker

This feature provides thermal-magnetic circuit breakers with higher Ampere Interrupting Capacity ratings than the standard. See the tables on Page 11 for medium and high AIC breaker ratings.

ORDERING	
FACTORY INSTALLATION <b>YES</b>	Factory Installation use Specification Table on page 11
AVAILABLE FOR FIELD INSTALLATION <b>YES</b>	Contact factory with serial number of original unit and type of breaker upgrade for proper field kit parts.



### AC Input and/or DC Output Fuses

Default protection devices for the AT30 are molded case circuit breakers. Fuses may also be ordered to augment them, wired in series with the breakers. Three (3) ac input fuses provide 200 kAIC protection. Two (2) dc output fuses provide 20 kAIC protection. Fuses may also be ordered in conjunction with standard breakers as a cost-saver. If an AT30 is ordered without breakers, fuses must be ordered.

ORDERING	
FACTORY INSTALLATION <b>YES</b>	Factory Installation use Specification Table on page 11
AVAILABLE FOR FIELD INSTALLATION <b>YES</b>	Contact factory with serial number of original unit and type of fuses (ac and/or dc) for proper field kit parts.

# CUSTOMIZE YOUR AT30

OPTIONS THAT LET YOU DESIGN YOUR CHARGER EXACTLY HOW YOU NEED IT!

	<h3>Auxiliary Alarm Relay Board</h3> <p>The AT30 features several industry-standard alarms, with individual LED indicators on the front instrument panel, and are accessible to the user via one (1) Summary Alarm contact on the Main Control PC Board. This feature provides a separate user-accessed pc board, featuring discreet two (2) form-C relay contacts for all six (6) alarms.</p>	<b>FACTORY INSTALLATION</b> <b>YES</b>	<b>ORDERING</b> Factory Installation use Specification Table on page 11
		<b>AVAILABLE FOR FIELD INSTALLATION</b> <b>YES</b>	Field Installation use Part Number Style 5018: <i>EI0213-02</i> Style 5030: <i>EI0213-03</i> Style 163: <i>EI0213-04</i> Style 198: <i>EI0213-05</i>

	<h3>Copper Ground Bus</h3> <p>This option provides a convenient means to tie the AT30 to the site building ground. A copper ground bus bar is provided with an extra CU-AL compression box lug.</p>	<b>FACTORY INSTALLATION</b> <b>YES</b>	<b>ORDERING</b> Factory Installation use Specification Table on page 11
		<b>AVAILABLE FOR FIELD INSTALLATION</b> <b>YES</b>	Field Installation use Part Number Style 5018: <i>EI0195-02</i> Style 5030: <i>EI0195-03</i> Style 163: <i>EI0195-04</i> Style 198: <i>EI0195-04</i>

	<h3>AC Lightning Arrestor</h3> <p>This options features an industrial-grade surge arrestor in polycarbonate housing, rated for 20,000 Amperes. It is recommended for installations with risk of frequent ac surges, such as high elevations or severe weather.</p>	<b>FACTORY INSTALLATION</b> <b>YES</b>	<b>ORDERING</b> Factory Installation use Specification Table on page 11
		<b>AVAILABLE FOR FIELD INSTALLATION</b> <b>YES</b>	Field Installation use Part Number <i>EJ1074-02</i>

	<h3>Fungus Proofing</h3> <p>This treatment is also referred to as "tropicalization". It coats electrical components and internal wiring connections with a fungus-resistant, non-conductive film (approx. 1 mil thickness). User termination points are not coated, nor are relay contacts, and any electrical connectors where the spray would interfere with functionality. The application is fully cured at time of shipment.</p>	<b>FACTORY INSTALLATION</b> <b>YES</b>	<b>ORDERING</b> Factory Installation use Specification Tables on pages 10 & 11
		<b>AVAILABLE FOR FIELD INSTALLATION</b> <b>NO</b>	NOT AVAILABLE FOR FIELD INSTALLATION

	<h3>Static Proofing</h3> <p>Used in "arid" environments, this treatment coats electrical components and connections with a static-resistant, non-conductive film (approx. 1 mil thickness). User termination points are not coated, nor are relay contacts, and any electrical connectors where the spray would interfere with functionality. The application is fully cured at time of shipment.</p>	<b>FACTORY INSTALLATION</b> <b>YES</b>	<b>ORDERING</b> Factory Installation use Specification Tables on pages 10 & 11
		<b>AVAILABLE FOR FIELD INSTALLATION</b> <b>NO</b>	NOT AVAILABLE FOR FIELD INSTALLATION

# CUSTOMIZE YOUR AT30

OPTIONS THAT LET YOU DESIGN YOUR CHARGER EXACTLY HOW YOU NEED IT!

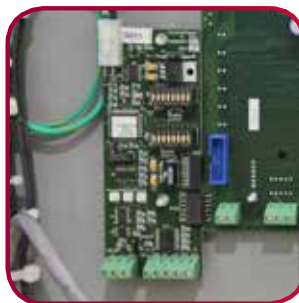

## Communications

This option allows full remote monitoring of the AT30 and control of the front panel features, using MODBUS or DNP3 Level 2 protocols. Standard serial connections are provided for use with local SCADA systems.

Ethernet or Fiber Optic Modem interfaces are also available for use with the AT Communications option. Contact factory for part number.

FACTORY  
INSTALLATION

YES

AVAILABLE FOR  
FIELD INSTALLATION

YES

### ORDERING

Factory Installation use  
Part Number when ordering  
12Vdc: *EJ5037-01*  
24Vdc: *EJ5037-02*  
48Vdc: *EJ5037-03*  
130Vdc: *EJ5037-04*

Field Installation use Part Number  
12Vdc: *EJ5037-11*  
24Vdc: *EJ5037-12*  
48Vdc: *EJ5037-13*  
130Vdc: *EJ5037-14*



## Temperature Compensation

Supplied in a kit, this option adjusts the AT30 dc output voltage up or down, in response to battery temperature fluctuations. Temperature is measured by an epoxy-enclosed thermistor. This probe is mounted on or near the battery, and connected by a cable to the Main Control PC Board. It is compatible with both lead-acid and nickel-cadmium batteries, and recommended for VRLA batteries. Cable lengths of 25, 50, 100, and 200 ft are available.

FACTORY  
INSTALLATION

NO

AVAILABLE FOR  
FIELD INSTALLATION

YES

### ORDERING

CAN BE ORDERED WITH CHARGER  
BUT MUST BE FIELD INSTALLED

Field Installation use Part Number  
25ft: *EJ5033-00*  
50ft: *EJ5033-01*  
100ft: *EJ5033-02*  
200ft: *EJ5033-03*



## Barrier Type Alarm Terminal Blocks

This option features a separate molded phenolic terminal block, wired directly to the Auxiliary Alarm Relay PC Board. It allows the user to connect remote alarm wiring with ring or spade type lugs. The #6-32 binder head screw terminals are rated for 20A at 150 Vac/Vdc, and accept wire sizes #16 to #14 AWG.

FACTORY  
INSTALLATION

YES

AVAILABLE FOR  
FIELD INSTALLATION

YES

### ORDERING

Factory & Field Installation use  
Part Number when ordering

(1) FORM-C: *EJ5130-01*  
(2) FORM-C: *EJ5130-02*



## Mechanical Lock For Front Door

The AT30 front panel controls can be disabled by setting a jumper on the back of the Main Control PC board. For installations where extra security is required, the front instrument panel, or door, can be physically locked closed. This option provides a locking provision on the enclosure, a padlock, and two (2) keys. A fully installed door key lock is also available.

FACTORY  
INSTALLATION

YES

AVAILABLE FOR  
FIELD INSTALLATION

Padlock - YES  
Keylock - NO

### ORDERING

Factory & Field Installation use  
Part Number when ordering

Padlock Style 5018: *EI0215-00*  
Padlock Style 5030: *EI0215-01*  
Padlock Style 163: *EI0215-02*  
Padlock Style 198: *EI0215-03*  
Keylock Style 5018: *EI0215-11*  
Keylock Style 5030: *EI0215-12*  
Keylock Style 163: *EI0215-13*  
Keylock Style 198: *EI0215-14*



## Custom Paint

AT30 NEMA Type 1 enclosures feature an ANSI 61 gray epoxy powdercoat finish. Custom exterior and interior (e.g. semigloss white) colors are available in ANSI, PMS, and RAL color codes to meet specific requirements.

FACTORY  
INSTALLATION

YES

AVAILABLE FOR  
FIELD INSTALLATION

NO

### ORDERING

*EI5064-00*  
SPECIFY WHEN PLACING ORDER  
USING YOUR SPECIFIC PAINT  
REQUIREMENTS

NOT AVAILABLE FOR  
FIELD INSTALLATION

# CUSTOMIZE YOUR AT30

OPTIONS THAT LET YOU DESIGN YOUR CHARGER EXACTLY HOW YOU NEED IT!

	<h3>Wall Mounting Brackets or Rack Mounting</h3> <p>AT30 Chargers in Style-5018 enclosures can be wall or rack mounted. Wall-mounting brackets (EI5080-00) are shipped as a field kit. Use of this option increases the vertical footprint of the charger by 14". Anchor bolts are not supplied.</p> <p>The Style-5018 enclosure is also EIA 23" or 24" rack mountable. Mounting brackets (EI0193-03) are factory installed. Relay rack mounting hardware is not supplied.</p>	<b>FACTORY INSTALLATION</b> <b>Wall - No</b> <b>Rack - Yes</b>	<b>ORDERING</b> Factory & Field Installation use Part Number when ordering  <b>WALL MOUNTING</b> Style-5018: <i>EI5008-00</i>  <b>RACK MOUNTING</b> Style-5018 (23/24in): <i>EI0193-03</i>
		<b>AVAILABLE FOR FIELD INSTALLATION</b> <b>YES</b>	

	<h3>NEMA Type 2 Drip Shield</h3> <p>Standard AT30 battery chargers are supplied in NEMA Type 1 vented enclosures. The optional drip shield prevents overhead water and small falling particles from entering the top vented panels, protecting internal equipment from damage. The combined standard enclosure and drip shield meets the NEMA Type 2 specification.</p>	<b>FACTORY INSTALLATION</b> <b>YES</b>	<b>ORDERING</b> Factory & Field Installation use Part Number when ordering  STYLE 5018: <i>EI0191-02</i> STYLE 5030: <i>EI0191-03</i> STYLE 163: <i>EI0191-04</i> STYLE 198: <i>EI0191-05</i>
		<b>AVAILABLE FOR FIELD INSTALLATION</b> <b>YES</b>	

	<h3>NEMA Type 4 Cabinet</h3> <p>With this accessory, a fully assembled standard AT30 NEMA-1 vented enclosure is installed within another gasketed, sealed cabinet. The combined assembly meets the NEMA Type 4 (and therefore Type 12 and 13) enclosure specification. All ratings feature forced cooling, with user-supplied 120Vac for the fan.</p>	<b>FACTORY INSTALLATION</b> <b>YES</b>	<b>ORDERING</b> Factory Installation use Part Number when ordering Style 5018: <i>EI5037-00</i> Style 5030: <i>EI5057-00</i> Style 163: <i>EB5039-00</i> Style 198: <i>EB5046-00</i>
		<b>AVAILABLE FOR FIELD INSTALLATION</b> <b>YES</b>	

<b>SUPPLEMENTAL PRODUCT</b>		<b>ORDERING</b>	
	<h3>Fan Control Contactor</h3> <p>Lead-acid batteries produce hydrogen gas. This small wall-mounted external accessory provides a relay contactor to activate a battery installation vent or exhaust fan. Available in 10A or 20A models, the accessory is factory-set to provide relay closure when the AT30 enters into Equalize mode.</p>	<b>FACTORY INSTALLATION</b> <b>NO</b>	<b>CAN BE ORDERED WITH CHARGER BUT MUST BE FIELD INSTALLED</b>  Field Installation use Part Number 10 Amp Rating: <i>EJ5017-0#</i> 20 Amp Rating: <i>EJ5017-1#</i> <i>Contact manufacturer for specific part number</i>
		<b>AVAILABLE FOR FIELD INSTALLATION</b> <b>YES</b>	

<b>SUPPLEMENTAL PRODUCT</b>		<b>ORDERING</b>	
	<h3>AT-DC Distribution Panel</h3> <p>This product augments AT30 with a customized dc distribution panel for user-specified loads. The AT-DC is configurable to various combinations of main and branch breakers. The AT-DC panel is optimally supplied from the factory, mounted to the AT30 and pre-wired to the charger's dc output terminals. For further details, refer to the AT-DC product literature (JF5032-00).</p>	<b>FACTORY INSTALLATION</b> <b>YES</b>	<b>Factory &amp; Field Installation use Part Number when ordering</b>  <b>EJ5110-##</b>  <i>Refer to document (JF5032-00) for model specific part number.</i>
		<b>AVAILABLE FOR FIELD INSTALLATION</b> <b>YES</b>	

# AT30 SERIES SPECIFICATION CHART

Electronic File: click chart for printable PDF

DC Output Rating		AC Input Ampere Rating								Battery Charger AC Circuit Breaker Ampere Rating										
		Based on maximum rms value of the input current delivered to the charger under all operating conditions within manufacturer's specifications								(standard AIC breakers)										
Volts	Amps	208 VAC	220 VAC	240 VAC	380 VAC	416 VAC	440 VAC	480 VAC	600 VAC	208 VAC	220 VAC	240 VAC	380 VAC	416 VAC	440 VAC	480 VAC	600 VAC			
(12Vdc) Float Adjust 11.0-14.5Vdc	12Vdc	50	5	5	4	3	3	2	2	2	10	10	10	5	5	5	5	15		
		75	7	6	6	4	3	3	3	3	10	10	10	5	5	5	5	15		
		100	9	8	8	5	5	4	4	4	15	10	15	10	10	5	5	15		
		125	12	11	10	6	6	5	5	5	15	15	15	10	10	10	10	15		
		150	13	13	12	9	7	6	6	6	20	20	20	15	15	10	10	15		
		200	16	16	14	9	9	8	7	6	20	20	20	15	15	10	15	15		
		250	22	20	19	12	11	10	9	8	30	25	30	15	15	15	15	15		
(12Vdc) Equalize Adjust 11.7-15.5Vdc	12Vdc	300	28	24	24	14	13	12	12	11	35	30	35	20	20	15	15	15		
		(24Vdc) Float Adjust 22.0-29.5Vdc	24Vdc	50	9	9	8	5	5	6	4	4	15	15	15	10	10	10	10	15
				75	12	11	10	7	6	5	5	5	15	15	15	10	10	10	10	15
				100	16	15	14	9	8	7	7	6	20	20	20	15	15	10	10	15
				125	21	20	18	11	10	9	9	8	30	25	30	15	15	15	15	15
				150	23	24	21	12	12	11	11	10	35	30	35	20	20	15	15	15
				200	27	28	25	16	14	13	13	11	40	35	40	25	25	20	20	15
250	39			37	34	22	20	19	17	15	50	50	50	30	30	25	25	20		
300	51			44	44	25	23	22	22	19	70	60	70	35	35	30	30	25		
400	59			59	51	34	32	30	27	24	80	80	80	50	50	40	40	35		
500	72			72	63	42	38	36	32	29	90	90	90	60	60	50	40	40		
600	88	87	76	51	46	44	40	35	125	125	125	70	70	60	50	50				
800	122	119	107	67	62	57	55	48	175	175	175	90	90	80	70	70				
1000	152	148	133	84	77	72	68	60	200	200	200	125	125	100	90	80				
(48Vdc) Float Adjust 44.0-58.0Vdc	48Vdc	50	15	13	13	8	8	7	7	6	20	20	20	15	15	10	10	15		
		75	20	19	16	11	10	10	9	8	25	25	25	15	15	15	15	15		
		100	26	25	24	13	13	12	12	10	35	35	35	20	20	15	15	15		
		125	35	33	29	19	18	17	15	13	50	50	50	25	25	25	20	20		
		150	37	35	32	20	19	18	16	14	50	50	50	25	25	25	20	20		
		200	53	50	46	29	27	25	23	20	70	70	70	40	40	35	30	25		
		250	69	66	58	38	35	33	30	26	100	100	100	50	50	50	40	40		
		300	78	74	68	43	39	37	34	30	100	100	100	60	60	50	50	40		
		400	100	96	88	56	51	48	44	39	125	125	125	70	70	60	60	50		
		500	128	120	110	70	64	60	55	48	175	175	175	90	90	80	70	70		
600	157	149	135	85	79	75	69	60	200	200	200	125	125	100	90	80				
800	209	198	181	113	106	99	91	79	300	300	300	150	150	125	125	100				
1000	261	248	225	143	132	125	113	99	350	350	350	200	200	175	150	125				
(130Vdc) Float Adjust 110.0-141.0Vdc	130Vdc	25	17	16	14	10	9	9	8	7	25	20	25	15	15	15	10	15		
		30	20	20	18	12	11	10	9	8	25	25	25	15	15	15	15	15		
		40	26	23	22	14	13	12	12	10	35	30	35	20	20	15	15	15		
		50	33	30	28	18	16	15	15	12	50	40	50	25	25	20	20	15		
		75	48	44	43	26	25	24	22	18	70	60	70	35	35	30	30	25		
		100	64	60	57	35	32	30	29	24	100	80	100	50	50	40	40	35		
		125	80	75	69	44	40	42	38	33	125	100	125	60	60	60	50	50		
		150	93	87	80	52	46	46	42	37	125	125	125	70	70	60	60	50		
		200	125	120	110	70	62	60	55	48	175	150	175	100	100	80	70	60		
		250	158	150	137	79	72	68	68	59	200	200	200	125	125	100	100	80		
		300	180	170	160	93	85	80	80	72	250	225	250	125	125	100	100	100		
		400	255	235	220	127	116	110	110	96	300	300	300	175	175	150	150	125		
		500	320	300	280	160	148	140	140	120	400	400	400	200	200	200	200	150		
		600	378	354	331	200	180	177	169	145	500	500	500	250	250	250	250	200		
800	503	473	439	266	241	233	224	194	N/A	N/A	N/A	350	350	300	300	250				
1000	628	590	547	330	300	291	279	240	N/A	N/A	N/A	450	450	400	350	300				



# HOW TO SIZE YOUR CHARGER

(simplified formula)

$$\left( \frac{Ah \times 1.R}{t} \right) + L = \text{Continuous Charger Output Rating}$$

Ah=Ampere hours removed  
 R= Recharge factor (1 = Pb) or (3 = NiCd)  
 L= Additional standing load  
 t= Recharge time in hours

Electronic File: click chart for printable PDF

DC Circuit Breaker Rating	Cabinet Style	Approx. Shipping Weights lb.(kg)	Heat Loss Watts (BTU/hr)
80	5018	260 (118)	229 (783)
100	5018	330 (150)	340 (1160)
150	5018	380 (173)	448 (1529)
175	5030	450 (205)	560 (1911)
200	5030	550 (250)	668 (2279)
250	5030	590 (268)	890 (3039)
350	5030	610 (277)	1113 (3799)
400	5030	650 (295)	1327 (4531)
80	5018	280 (127)	289 (987)
100	5018	340 (154)	427 (1457)
150	5018	390 (177)	560 (1911)
175	5030	540 (245)	700 (2309)
200	5030	580 (263)	833 (2843)
250	5030	610 (277)	1101 (3759)
350	5030	650 (295)	1376 (4699)
400	5030	690 (313)	1652 (5638)
600	163	1150 (522)	2202 (7518)
700	163	1300 (590)	2730 (9319)
800	163	1530 (694)	3275 (11183)
1200	198	2020 (916)	4367 (14910)
1200	198	2440 (1107)	5459 (18638)
80	5018	310 (141)	398 (1358)
100	5018	390 (177)	584 (1994)
150	5018	500 (227)	762 (2602)
175	5030	550 (250)	953 (3253)
200	5030	600 (272)	1131 (3860)
250	5030	660 (299)	1491 (5091)
350	5030	720 (327)	1864 (6363)
400	5030	760 (345)	2237 (7636)
600	163	1100 (499)	2949 (10068)
700	163	1350 (612)	3686 (12585)
800	198	1600 (726)	4424 (15102)
1200	198	2020 (916)	5898 (20137)
1200	198	2400 (1089)	7373 (25171)
40	5018	370 (168)	361 (1232)
50	5018	380 (172)	416 (1421)
60	5018	390 (177)	532 (1817)
80	5018	400 (182)	647 (2208)
100	5018	490 (222)	928 (3169)
150	5030	650 (295)	1201 (4099)
175	5030	740 (336)	1478 (5045)
200	5030	750 (340)	1773 (6054)
250	5030	820 (372)	2327 (7946)
350	163	1130 (513)	2909 (9932)
400	163	1330 (603)	3436 (11731)
600	163	1580 (717)	4582 (15641)
700	198	2150 (975)	5727 (19552)
800	198	2650 (1202)	6872 (23462)
1200	198	3250 (1474)	9163 (31283)
1200	198	4200 (1905)	11271 (38479)

## CABINET STYLES & DIMENSIONS

For detailed CAD drawings of all NEMA-1 type enclosures (and optional NEMA-4 (12) type enclosures), please visit the support section of our website [www.hindlepowerinc.com](http://www.hindlepowerinc.com)



Cabinet Style 5018

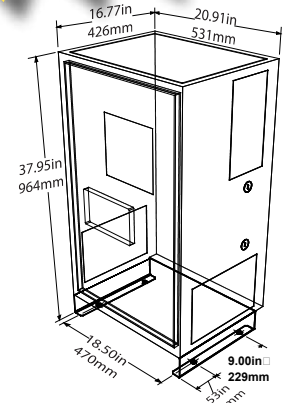

Cabinet Style 5030

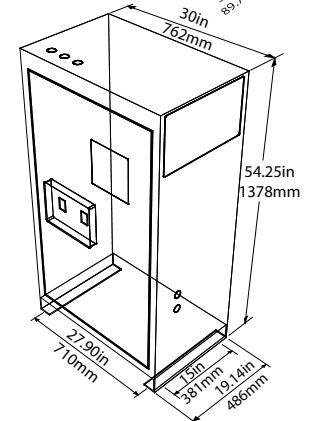

Cabinet Style 163

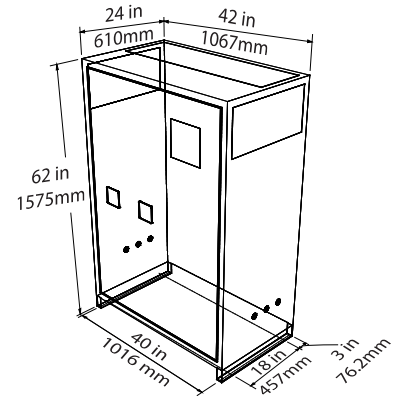

Cabinet Style 198

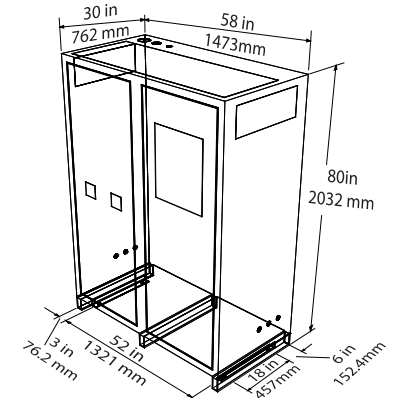

# STANARD INTERNAL LAYOUT BY CABINET STYLE

For detailed CAD drawings of all NEMA-1 type enclosures (and optional NEMA-4 (12) type enclosures), please visit the support section of our website [hindlepowerinc.com](http://hindlepowerinc.com)

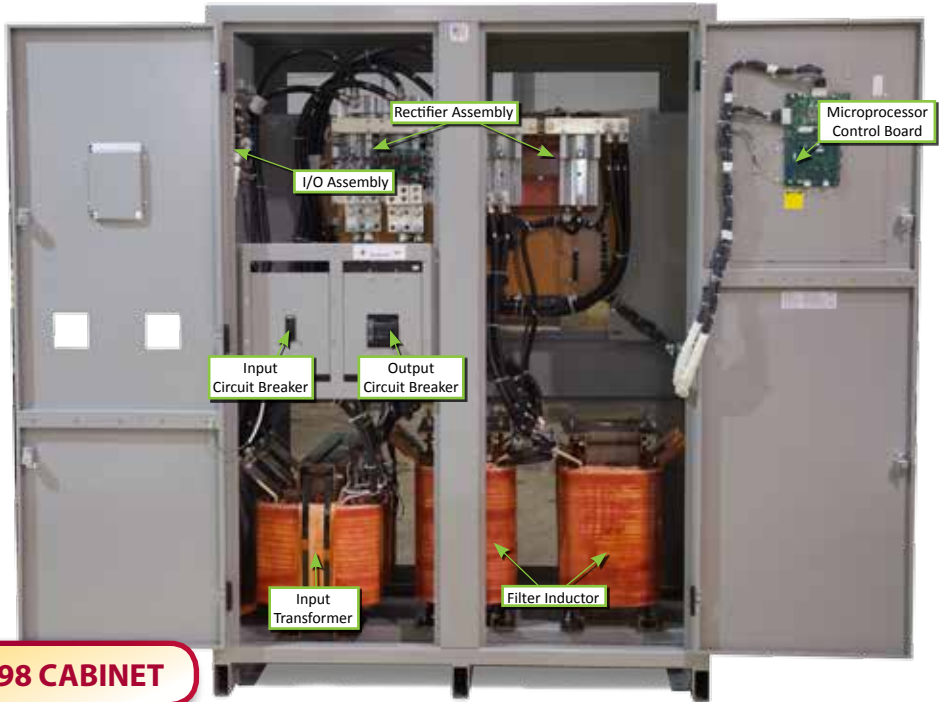
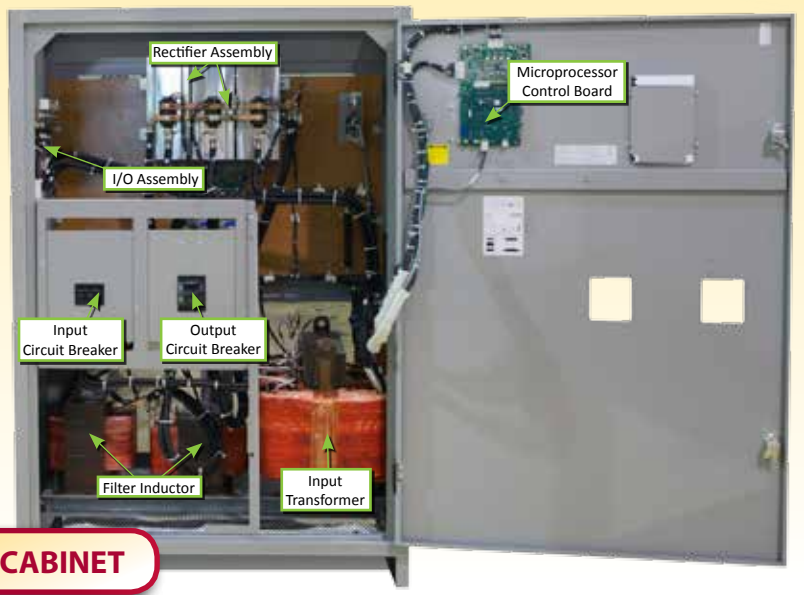
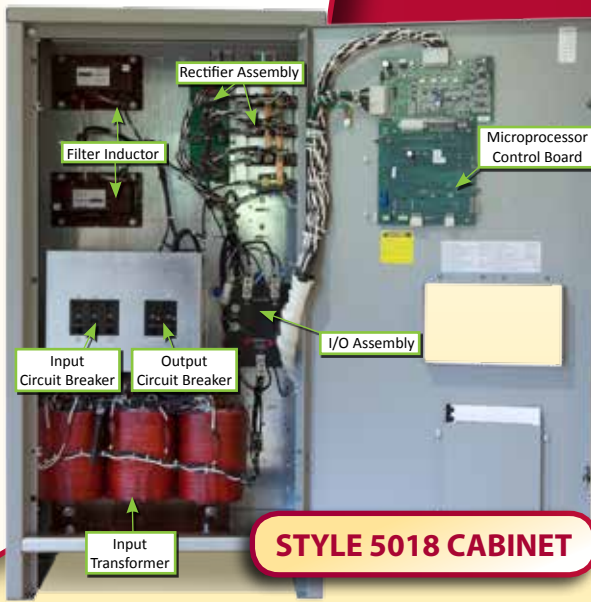

# AT30 - SPECIFICATION TABLE

	A	B			C			D	E			F	G	H	J	K	L	M	N	P
SAMPLE	AT30	1	3	0	0	5	0	F	4	8	0	S	X	S	X	A	X	X	X	X

YOUR CODE	AT30																			
-----------	------	--	--	--	--	--	--	--	--	--	--	--	--	--	--	--	--	--	--	--

	DESCRIPTION	CODE	FEATURE		DESCRIPTION	CODE	FEATURE
A		AT30	AT30 SERIES			S	Standard AIC
B	Nominal DC Output Voltage	012	12Vdc	F	AC Input Circuit Breaker Rating**	M	Medium AIC
		024	24Vdc			H	High AIC
		048	48Vdc			0	No Breaker
		130	130Vdc				
C	Nominal DC Output Current	025	25Adc	G	AC Input Fuses	F	Installed
		030	30Adc			X	Not Supplied
		040	40Adc	H	DC Output Circuit Breaker Rating**	S	Standard AIC
		050	50Adc			M	Medium AIC
		075	75Adc			H	High AIC
		100	100Adc			0	No Breaker
		125	125Adc	J	DC Output Fuses	F	Installed
		150	150Adc			X	Not Supplied
		200	200Adc	K	Auxiliary Alarm Relay Board	A	Installed
		250	250Adc			X	Not Supplied
		300	300Adc	L	Copper Ground Bus	G	Installed
		400	400Adc			X	Not Supplied
		500	500Adc	M	AC Lightning Arrestor	L	Installed
		600	600Adc			X	Not Supplied
		800	800Adc	N	Fungus Proofing	F	Applied
		1K0	1000Adc			X	Not Supplied
D	DC Output Filtering	U	Unfiltered	P	Static Proofing	S	Applied
		F	Filtered			X	Not Supplied
		E	Eliminator				
E	AC Input Voltage* (3~)	208	208V 60Hz	* Contact factory for other AC input voltages not listed ** If you do not order an AC input or DC output circuit breaker, fuses will be provided.			
		240	240V 60Hz				
		480	480V 60Hz				
		600	550/600V 60Hz				
		220	220V 50/60Hz				
		380	380V 50/60Hz				
		416	416V 50/60Hz				

### Circuit Breaker AC & DC Ratings

<p style="text-align: center; color: red; margin: 0;"><i>STANDARD</i></p> <p style="margin: 0;">Input: 5kAIC - 120/208/240/480Vac 14kAIC - 600Vac Output: 5kAIC - 125Vdc</p>	<p style="text-align: center; color: red; margin: 0;"><i>MEDIUM</i></p> <p style="margin: 0;">Input: 25kAIC - 120/208/240/480Vac 18kAIC - 600Vac Output: 10kAIC - 250Vdc</p>	<p style="text-align: center; color: red; margin: 0;"><i>HIGH</i></p> <p style="margin: 0;">Input: 65kAIC - 120/208/240/480Vac N/A - 600Vac Output: 20kAIC - 250Vdc</p>
--	--	---

# OUR UNRIVALED PRODUCT WARRANTY

## Standard Warranty

*(applies only to product(s) delivered within the United States and Canada)*

All HBL charger products are warranted to be free from defects in material and workmanship for a period of five (5) years from date of manufacture. During the term of the warranty period: parts, assemblies, or components deemed to be defective will be repaired or replaced at our option, free of charge. All costs related to removal, reinstallation and transportation will be paid by the purchaser/customer and/or operator of the product. Evaluation, repair and/or replacement of any defective part(s) are FOB manufacturer's factory.

This warranty does not cover products or parts that are damaged from improper use or abuse, as determined by HBL. Accessory items or additional items carry only their respective manufacturer's warranty. Consumable items (such as fuses and electrolytic capacitors), which wear out under normal use are specifically not covered by this standard warranty. Any consequential damage due to diagnosis or repair by any party other than HBL authorized personnel is not covered under this warranty.

**NOTE:** Requests for returns or claims must be submitted to our Factory Service Center for Return Material Authorization(RMA) instructions and assignment. Returns that do not follow this procedure will not be honored.



## Other Products Available from HBL:

AT10.1 Microprocessor Battery Charger	JF5006	UMC Universal Maintenance Charger	JF5008
AT Series Options & Accessories	JF5020	Single Cell Charger	JF5007
AT Series Communications Module	JF5014	Mobile DC Power System	JF5041
AT-DC Series Distribution Panel	JF5032	The EPIC Series Console	JF5043
SCR/SCRF Series Utility Battery Charger	JF5010	Best Battery Selector	JF5048



Mobile DC  
Power System



Universal  
Maintenance Charger



AT10.1 Microprocessor  
Battery Charger



The EPIC  
Series Console